

ood brown & sharpe®

*one*

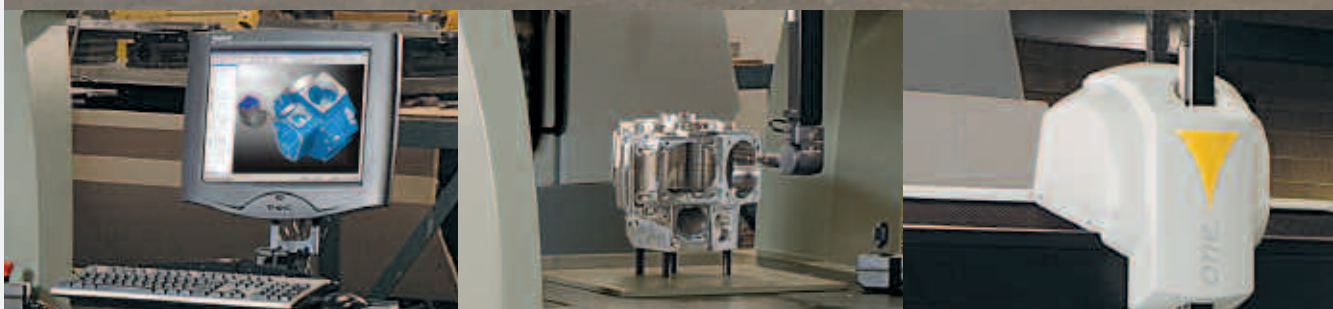

# one

## ...shop floor hardened measurement

The ONE Shop Floor CMM from Brown & Sharpe® is a precision measurement instrument designed and manufactured to withstand harsh shop floor environments. Put ONE anywhere you need it – from receiving inspection to manufacturing cells running side-by-side with machine tools. ONE uses linear recirculating ball bearings instead of air bearings, further enhancing its flexibility and ruggedness.

ONE is easy to use. PC-DMIS STI+ allows machine tool operators to measure parts with little or no training. Interpreting measurement results is a breeze with easy to recognize “go/no go” style graphical output.

Every ONE now includes an integrated flush granite work surface as a standard feature. The addition of a new scan ready package allows for incorporation of optional continuous contact analog scanning probes and accessories to perform form measurements right on the shop floor.

The ONE is installed and supported by Hexagon Metrology’s worldwide service and support network of metrology experts offering unmatched personalized assistance to our customers.

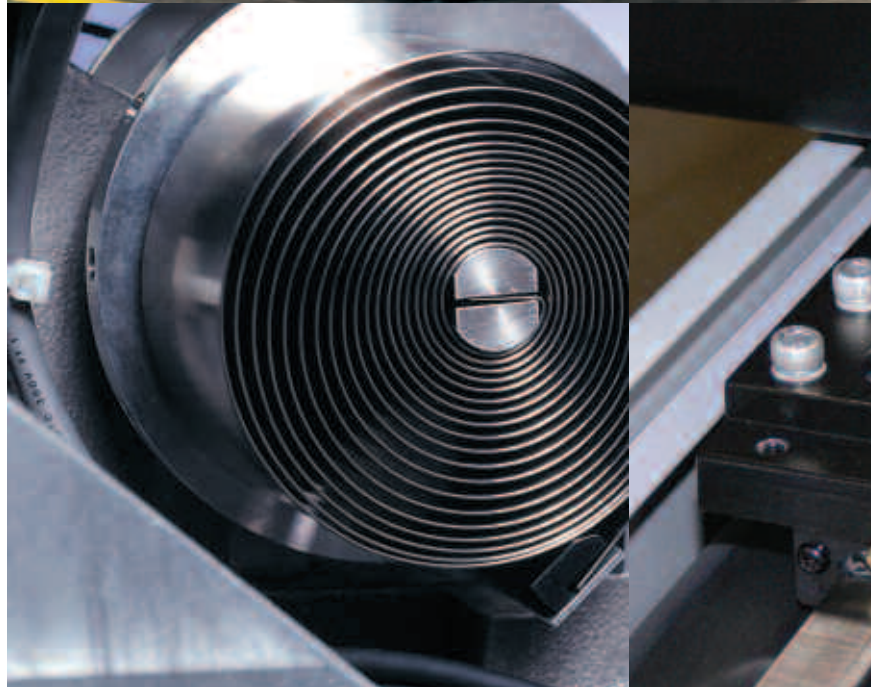

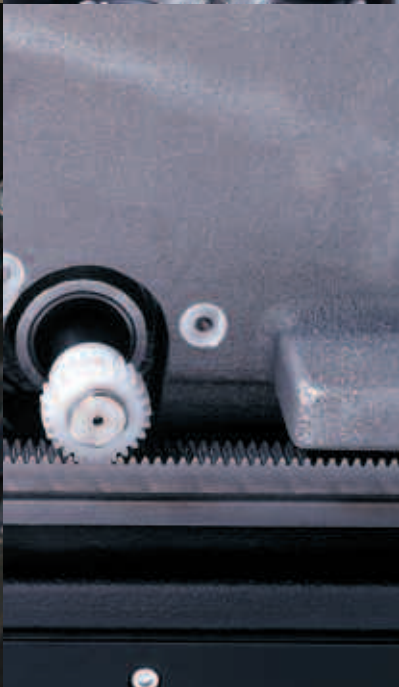
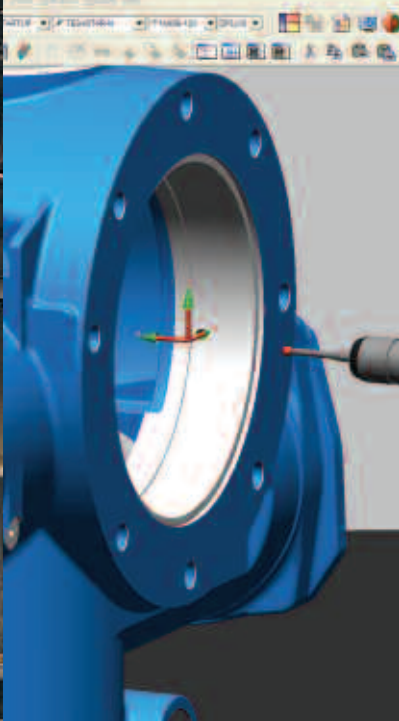

Advanced materials technology and design philosophy make ONE the only real choice for shop floor measurement and inspection applications. Thermal effects are minimized by design, including eliminating bimetallic interfaces and incorporating automatic temperature compensation algorithms. The one-piece polymer base provides superior vibration dampening characteristics compared to more traditional materials. Bellows covers protect critical components from airborne shop floor contaminants.

ONE's durable linear guides and recirculating bearings are sealed, require no lubrication, and are virtually maintenance free. The highly optimized motor and rack and pinion drive system provides repeatable machine positioning.

The performance of all ONE Shop Floor CMMs is checked and certified through the most rigorous application of test procedures as specified by either B89 or ISO standards. All aspects of our business, from product design and manufacturing to delivery and customer service have been reviewed and found to meet the internationally accepted ISO 9001:2000 quality standard.

# one

ONE is offered in three pre-configured packages and includes a wealth of options to suit most every shop floor measurement application.

## Standard Package Summary

The most cost effective solution to shop floor measurement.

Probe: TESASTAR manual probe head  
Software: PC-DMIS Pro  
Accessories: Computer package, styli kit, installation, training, and warranty.

## Enhanced Package Summary

An advanced solution that includes an automatic indexing probe head and CAD programming capability.

Probe: Motorized probe head and touch trigger probe.  
Software: PC-DMIS CAD  
Accessories: Upgrade computer package and workstation desk, styli kit, work piece clamp kit, training part, installation, training, and warranty.

## Scan Ready Package

An advanced solution that includes a scanning enabled controller that opens up options for upgrading to continuous contact analog scanning probes and accessories.

Probe: Motorized probe head and touch trigger probe.  
Software: PC-DMIS CAD  
Accessories: Scanning enabled controller, pre-wired for scanning probes, optional scanning kit upgrades, upgrade computer package and workstation desk, styli kit, workpiece clamp kit, installation, training, and warranty.

An optional stand upgrade provides an ergonomic, stand alone CMM with a small footprint. The upgrade includes an articulating arm for mounting the computer monitor and keyboard. The machine stand is equipped with a shelved enclosure with locking door and viewing window to house the computer and probe peripherals. The printer is mounted on the exterior of the machine stand via its own support arm.



*Optional stand upgrade*



*The Power of Technology*

## TESASTAR Probe System

Hexagon Metrology now offers a complete range of Swiss-made probes which are designed for use on our coordinate measuring machines. TESA engineers have designed a complete group of components for coordinate measurement – including styli, extensions and accessories.

### TESASTAR probe

The entry level product in the TESASTAR product family, this probe head is fitted with a touch probe with adjustable trigger force. The compact TESASTAR is especially convenient for small CMMs. It can be manually swiveled to an infinite number of positions.

### TESASTAR-i indexing probe head

TESASTAR-i features repeatable indexing coupled with a high-precision integrated touch probe. The indexing capability in 15° increments in both axes allows the stylus to swivel through 168 positions without the need for recalibration. The A and B positions are clearly indicated in separate windows on the probe, so that the precise angle can be viewed at a glance. Indexing between positions is an easy, one-handed operation; tactile and visual feedback lets you know when the probe is ready to measure.

### TESASTAR-m motorized probe head

TESASTAR-m is a motorized articulating probe head for CMMs that is capable of indexing in 5 degree increments, +180 degrees to -180 degrees in revolution, and +90 to -115 degrees in pitch. This translates to a total of 2,952 possible positions, including a unique “table-hugging” 90 degree horizontal position possible due to the indexing arm’s asymmetrical shape. The head also features high speed indexing, with faster index changes than similar products.

The robust aluminum construction and rugged design permits extension rods with lengths up to 300 mm. The TESA kinematic joint connection on the TESASTAR-m accepts multi-wired probes, or, coupled with an M8 adaptor can be used with TESA touch trigger probes as well as other probe brands.

### TESASTAR-p touch trigger probe

The TESASTAR-p is an M8 threaded 5-way touch probe. There are four variations available, providing variable trigger force from 0.05 N to 0.10 N.

### TESASTAR-r probe autochange rack

Used in automatic exchange mode, TESASTAR-r coupled with the TESASTAR-m motorized probe head is a fully automatic active probe changing solution, which accommodates multiple probe types, with or without extensions. The rack is also fully modular, and can be configured with three to nine changing ports, or any number in between. You don’t have to buy ports you don’t need, and you can add one or more ports later should your needs change.

### TESA stylus kits

TESA offers a full range of standard ruby-tipped styli for general measurement applications. These styli are compatible with standard probes from any manufacturer.

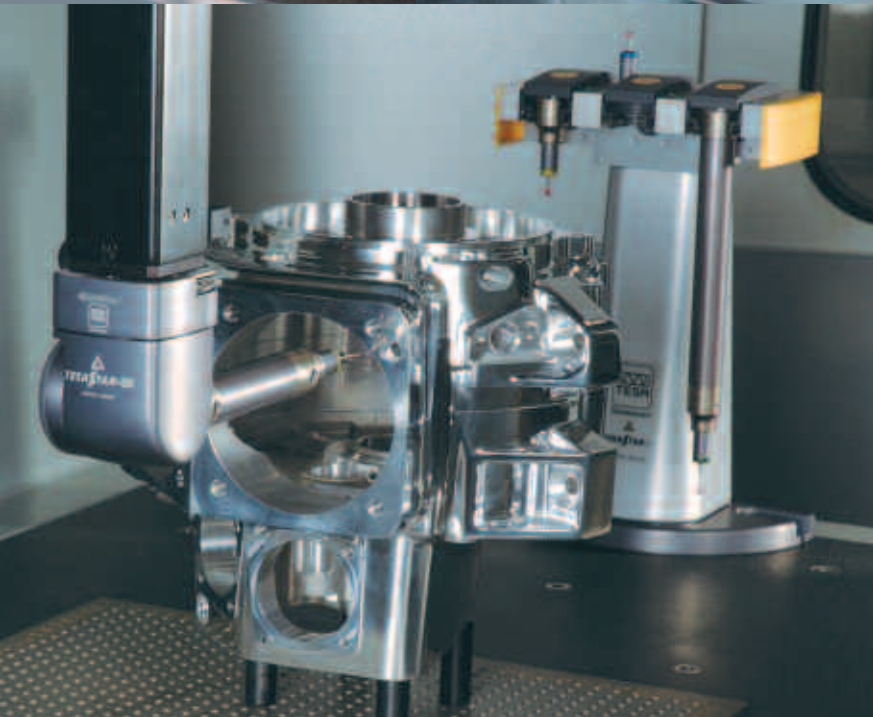

## STI+

Single Touch Interface™ (STI+) makes it easy to add custom front ends to PC-DMIS. STI+ allows non-CMM experts to set up and run inspection programs with minimal training, and specifically targets organizations where machine operators and other shop floor staff need to check their work but don't have time to become CMM experts.

Single Touch Interfaces themselves are infinitely variable – they can be as simple as a single screen that lets an operator launch one of several part programs, or as complex as a system capable of automatically locating a part on the CMM then calling up the appropriate part program to measure it. The STI+ option has two modules: one to develop the STI+ and the other to execute it.

CMM programmers develop Single Touch Interfaces using a “Slide Show” Editor. This is an application, similar to Microsoft's PowerPoint®, that lets them combine setup instructions, measurement programs, reporting templates, and everything else they need to measure parts into a single, cohesive system. Whatever the level of sophistication, ONE and STI+ bring metrology to where it's needed most: the shop floor. STI+ not only makes it easy for the non-specialist to take advantage of the most sophisticated measurement equipment available, it ensures that parts are checked more frequently, results are ready immediately, and minor glitches do not grow into major problems.

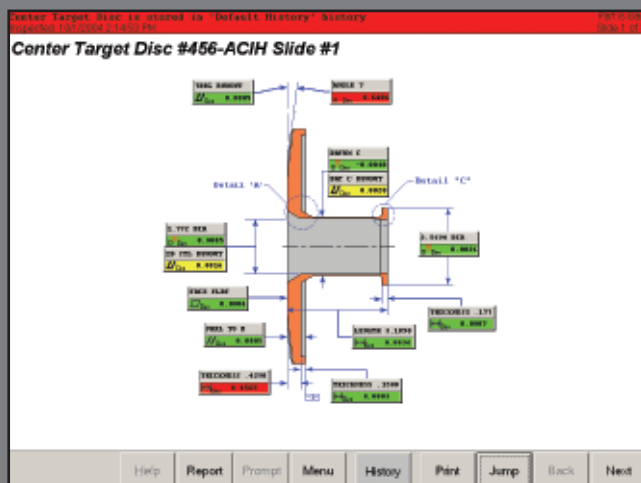

Visually alert operators to problems

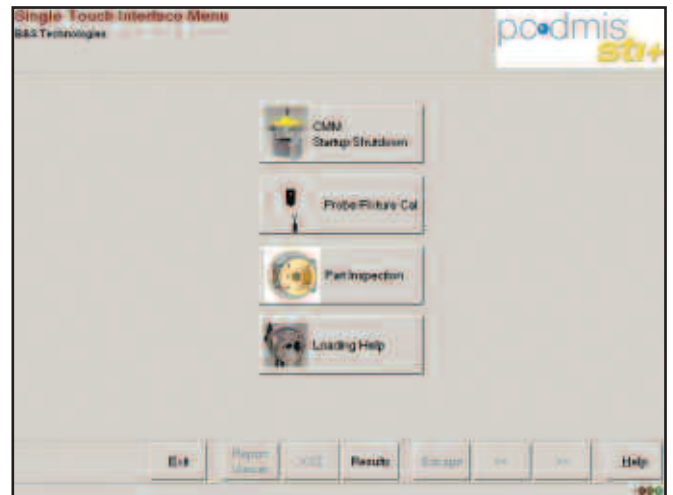

Inspect complex parts with a mouse click

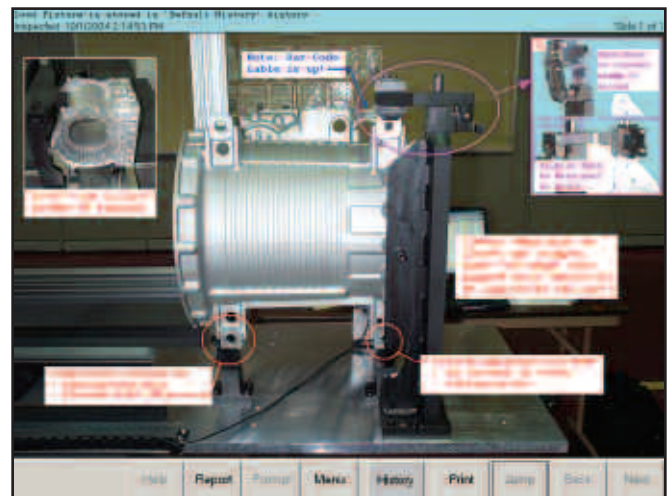

Embed digital photos, movies and sound into the STI

STI+ is available as an option for PC-DMIS PRO, CAD, and CAD++. STI+ allows you to:

- Create custom user interfaces without needing high-level programming skills.
- Guide users effortlessly through complex operations with easy-to-use menus, prompts, and automatic routines.
- Take full advantage of PC-DMIS's capabilities while isolating the inspectors from complexities.
- Build in routines to manage hardware devices; automate machine startup, error recovery, and probe calibration; and support external devices like bar code readers for part recognition.
- Add job and part specific help files.

## PC-DMIS® Inspection software

PC-DMIS measurement and inspection software provides the most comprehensive solution to any kind of metrology application. PC-DMIS is available in three different versions and with a number of options packages.

### PC-DMIS PRO® full-featured metrology software



PC-DMIS PRO provides an intuitive graphical user interface (without CAD), including a suite of wizards to help operators quickly learn and manipulate key inspection functions.

Features include:

- A full programming environment including high level programming functions.
- Customizable menus.
- Quick Start™ routines for probe qualifications, part alignments and hyper reporting functions.
- A full suite of customizable reporting and advanced Hyper Reporting tools.
- Intuitive Probe and Go™ to automatically recognize feature types and create interactive graphical part representations.

### PC-DMIS CAD® adds the ability to import CAD files



PC-DMIS CAD includes all PC-DMIS PRO functionality, plus:

- Full 3D animation capability including digitized images of parts and fixtures on the machine so operators can visually verify the set-up and program prior to actual part inspection.
- Unknown part documentation to generate computer models for reverse engineering applications.
- Link to CAD bi-directionally using built-in DES, DMIS, DWG, DXF, IGES, STEP, STL, VDAFS, and XYZIJK translators.
- A Direct CAD Interface™ (DCI) option to create part programs directly from CAD models utilizing the native CAD system algorithms and tools. Connect to many popular CAD systems, including Unigraphics, Solidworks, Pro-E, CATIA V5, IDEAs, and ACIS.
- A Direct CAD Translator™ (DCT) option allows the use of a native CAD model even when the specific CAD system is not owned by the user. Transform files from a variety of CAD systems, such as Unigraphics, Pro-E, and CATIA V5.

### PC-DMIS CAD® ++ adds scanning And thin-walled parts



In addition to all PC-DMIS PRO and PC-DMIS CAD functionality, PC-DMIS CAD++ incorporates scanning and digitizing functions that allow fast and efficient measurement of complex shapes such as turbine blades, dies, models, sheet metal components and other curved shapes.

Features include:

- Rotary, patch, linear open and closed loop scanning.
- Perimeter, section, UV and edge point scanning.
- Complete probe simulation.
- Full thin-wall feature measurement suite.

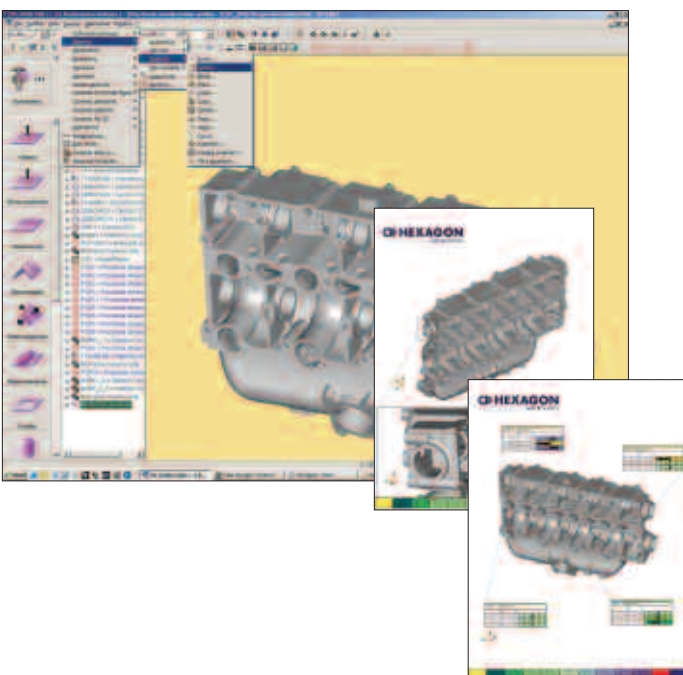
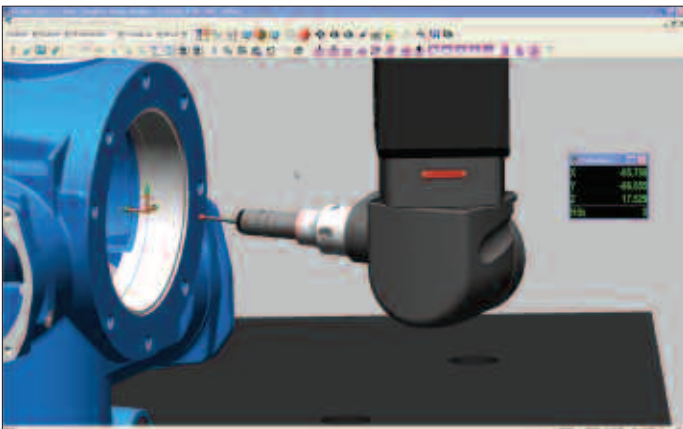
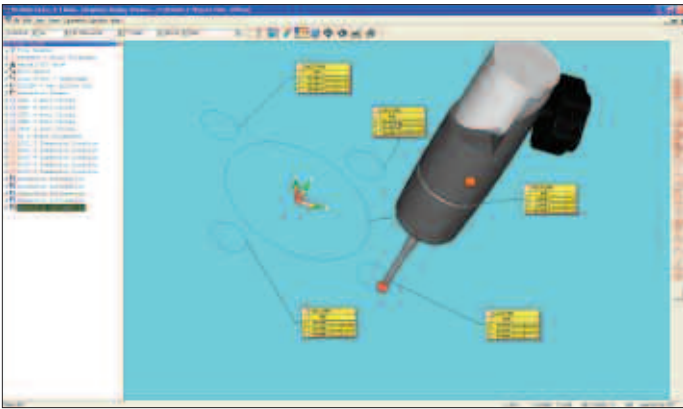



MODELS	STROKES mm (in)		
	X	Y	Z
7.7.5	700 (27.6)	700 (27.6)	500 (19.7)
7.10.7	700 (27.6)	1000 (39.4)	650 (25.6)

**brown & sharpe®**

Hexagon Metrology, Inc., 250 Circuit Drive, North Kingstown, RI 02852  
 Tel: (800) 766-4673 (401) 886-2000 Fax: (401) 886-2727  
[www.browncandsharpe.com](http://www.browncandsharpe.com) [bwshp@us.bnsmc.com](mailto:bwshp@us.bnsmc.com)

**USA**

Elgin, IL Tel: (847) 931-0100 Fax: (847) 931-1979	Wixom, MI Tel: (248) 449-9400 Fax: (248) 449-7438	Miamisburg, OH Tel: (937) 247-0425 Fax: (937) 247-0426	Nashville, TN Tel: (615) 331-0800 Fax: (615) 331-0875	Lake Forest, CA Tel: (949) 916-4490 Fax: (949) 727-0167	Huntersville, NC Tel: (704) 947-1250 Fax: (704) 947-1277	Kent, WA Tel: (253) 872-2443 Fax: (253) 872-2579	Monterrey, Mexico Tel: 13 67 08 00 Fax: 13 67 08 01
---	---	--	---	---	--	--	---

ISO 9001 Certified



All specifications in this brochure are subject to change without notice.  
 © 2007 Brown & Sharpe Inc. All Rights Reserved. Printed in U.S.A. 80-80440-4 04/07